

QUADRANT MACHINISTS HANDBOOK

MACHINING PLASTICS MADE EASY

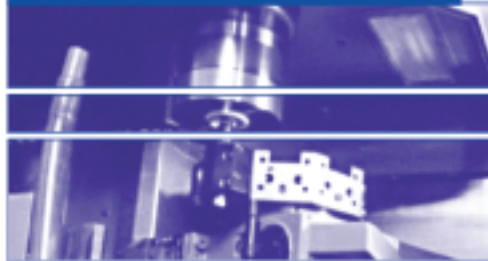

QUADRANT

You inspire ... we materialize®

The World's Leading Manufacturer of Plastic Stock Shapes.

Plastics increasingly replace traditional materials such as bronze, stainless steel, cast iron and ceramics. They are chosen for improved performance and cost reduction. Plastics can:

- **Reduce Weight**
- **Eliminate Corrosion**
- **Improve Wear Performance in Unlubricated Conditions**
- **Reduce Noise**
- **Increase Part Life**
- **Insulate & Isolate, Both Thermally and Electrically**

Typical applications for engineering plastics range from semiconductor processing equipment components to heavy equipment wear parts, to food processing industry components.

Machinable plastic stock shapes (sheet, rod, and tubular bar) are now available in more than 50 grades, spanning the performance/price range of both ferrous and non-ferrous metals to specialty ceramics. Plastics capable of long term service up to 800°F (425°C), with short term exposures to 1,000°F (540°C) are now available. As the number of material options has increased, so has the difficulty of selecting the right material for a specific application.

Table of Contents

Fabrication Guidelines	2-8
Machinability.....	9-10
Drilling Guidelines.....	11-12
Troubleshooting - Drilling	13-14
Sawing Guidelines	15-16
End Milling / Slotting Guidelines.....	17-18
Face Milling.....	19-20
Troubleshooting - Turning & Boring.....	21
Troubleshooting - Cutting Off	22
Turning Guidelines	23-24
Annealing.....	25-26
Air Annealing Guidelines	27-30
Diagrams	31-32
Conversions.....	33-34

FABRICATION GUIDELINES

Please return to:

Name:

Company:

Dept:

Address:

City:

State:

Zip:

Phone

E-mail

The following guidelines are presented for those machinists not familiar with the machining characteristics of plastics. They are intended as guidelines only, and may not represent the most optimum conditions for all parts. The troubleshooting quick reference guides in this booklet should be used to correct undesirable surface finishes or material responses during machining operations.

All Quadrant materials are stress relieved to ensure the highest degree of machinability and dimensional stability. However, the relative softness of plastics (compared to metals) generally results in greater difficulty maintaining tight tolerances during and after machining. A good rule of thumb for tolerances of plastic parts is +/- .001" per inch of dimension although tighter tolerances are possible with very stable, reinforced materials.

When machining Quadrant stock shapes, remember...

- *Thermal expansion is up to 10 times greater with plastics than metals*
- *Plastics lose heat more slowly than metals, so avoid localized overheating*
- *Softening (and melting) temperatures of plastics are much lower than metals*
- *Plastics are much more elastic than metals*

Because of these differences, you may wish to experiment with fixtures, tool materials, angles, speeds and feed rates to obtain optimum results.

Getting Started

- *Positive tool geometries with ground peripheries are recommended*
- *Carbide tooling with ground top surfaces is suggested for optimum tool life and surface finish. Polycrystalline diamond tooling provides optimum surface finish when machining Duratron® PBI.*
- *Use adequate chip clearance to prevent clogging*
- *Adequately support the material to restrict deflection away from the cutting tool*

Coolants

Coolants are generally not required for most machining operations (not including drilling and parting off). However, for optimum surface finishes and close tolerances, non-aromatic, water soluble coolants are suggested. Spray mists and pressurized air are very effective means of cooling the cutting interface. General purpose petroleum based cutting fluids, although suitable for many metals and plastics, may contribute to stress cracking of amorphous plastics such as Quadrant PC 1000, Quadrant PSU, Duratron® U1000 PEI, and Quadrant PPSU.

Machining Tips

- Coolants are strongly suggested during drilling operations, especially with notch sensitive materials such as Ertalyte® PET-P, Duratron® PAI, Duratron® PBI and glass or carbon reinforced products.*
- In addition to minimizing localized part heat-up, coolants prolong tool life. Two (flood) coolants suitable for most plastics are Trim E190 and Trim Sol LC SF (Master Chemical Corporation – Perrysburg, OH).*

Threading and Tapping

Threading should be done by single point using a carbide insert and taking four to five 0.001" passes at the end. Coolant usage is suggested. For tapping, use the specified drill with a two flute tap. Remember to keep the tap clean of chip build-up. Use of a coolant during tapping is also suggested.

Milling

Sufficient fixturing allows fast table travel and high spindle speeds when end milling plastics. When face milling, use positive geometry cutter bodies.

Sawing

Band sawing is versatile for straight, continuous curves or irregular cuts. Table saws are convenient for straight cuts and can be used to cut multiple thicknesses and thicker cross sections up to 4" with adequate horsepower. Saw blades should be selected based upon material thickness and surface finish desired.

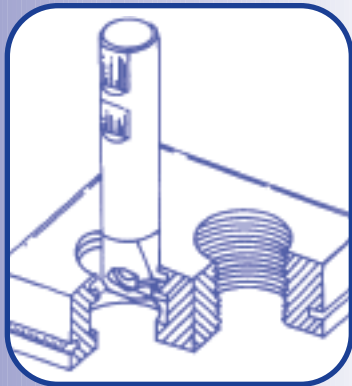

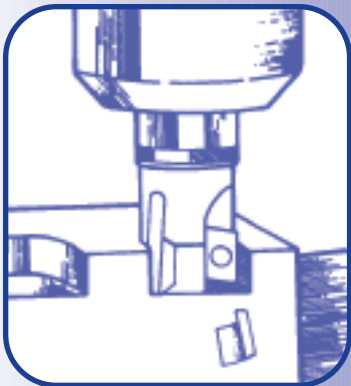

Sawing Tips

- Rip and combination blades with a 0° tooth rake and 3° to 10° tooth set are best for general sawing in order to reduce frictional heat.
- Hollow ground circular saw blades without set will yield smooth cuts up to $3/4$ " thickness.
- Tungsten carbide blades wear well and provide optimum surface finishes.

Drilling

The insulating characteristics of plastics require consideration during drilling operations, especially when hole depths are greater than twice the diameter.

Small diameter holes (1/32" to 1" diameter)

High speed steel twist drills are generally sufficient for small holes. To improve swarf removal, frequent pull-out (peck drilling) is suggested. A slow spiral (low helix) drill will allow for better swarf removal.

Large diameter holes (1" diameter and larger)

A slow spiral (low helix) drill or general purpose drill bit ground to a 118° point angle with 9° to 15° lip clearance is recommended. The lip rake should be ground (dubbed off) and the web thinned.

It is generally best to drill a pilot hole (maximum 1/2" diameter) using 600 to 1,000 rpm and a positive feed of 0.005" to 0.015" per revolution. Avoid hand feeding because of the drill grabbing which can result in microcracks forming. Secondary drilling at 400 to 500 rpm at 0.008 to 0.020" per revolution is required to expand the hole to larger diameters.

A two step process using both drilling and boring can be used on notch sensitive materials such as Ertalyte® PET-P and glass reinforced materials. This minimizes heat build-up and reduces the risk of cracking.

1. Drill a 1" diameter hole using an insert drill at 500 to 800 rpm with a feed rate of 0.005" to 0.015" per revolution.
2. Bore the hole to final dimensions using a boring bar with carbide insert with 0.015" to 0.030" radii at 500 to 1,000 rpm and a feed rate of 0.005 to 0.010" per revolution.

Turning

Turning operations require inserts with positive geometries and ground peripheries. Ground peripheries and polished top surfaces generally reduce material build-up on the insert, improving the attainable surface finish. A fine grained C-2 carbide is generally best for turning operations.

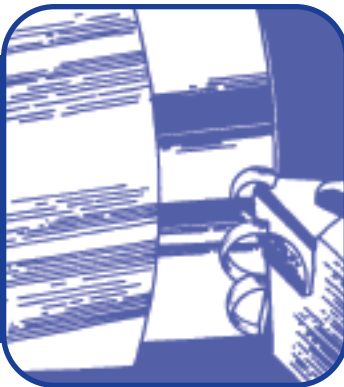

Machinability

**Relative
Machinability
(1 to 10
1 = easiest)**

<i>Acetron® GP POM-C</i>	1
<i>Acetron® POM-H, Acetron® AF</i>	1
<i>Acetron® AF Blend</i>	1
<i>Duratron® CU60 PBI</i>	10
<i>Duratron® T4203 PAI</i>	5
<i>Duratron® T4301 PAI</i>	5
<i>Duratron® T4501 PAI</i>	6
<i>Duratron® T4503 PAI</i>	6
<i>Duratron® T4540 PAI</i>	6
<i>Duratron® T5530 PAI</i>	8
<i>Duratron® U1000 PEI & U2300 PEI</i>	7
<i>Ertalyte® PET-P</i>	2
<i>Ertalyte® TX PET-P</i>	2
<i>Fluorosint® MT01</i>	3
<i>Fluorosint® 500 PTFE</i>	1
<i>Fluorosint® 207 PTFE</i>	1
<i>Fluorosint® HPV</i>	1
<i>Ketron® 1000 PEEK</i>	5
<i>Ketron® GF30 PEEK</i>	7
<i>Ketron® CF30 PEEK</i>	7
<i>Ketron® HPV PEEK</i>	6
<i>Nylatron® MC901 PA6 & MC907 PA6</i>	1
<i>Nylatron® GS PA66 & GSM PA6</i>	1
<i>Nylatron® GSM Blue PA6 & NSM PA6</i>	2
<i>Quadrant Nylon 101 PA66</i>	1
<i>Quadrant PC 1000</i>	2
<i>Quadrant PSU</i>	3
<i>Quadrant PPSU</i>	3

Techtron® CM PSBG PPS	5
Techtron® PSBG PPS	5
Techtron® PPS	3
Techtron® HPV PPS	6

Semitron Materials -

Follow guidelines for most similar base resin

Base Resin

225	POM-C	1
410C	PEI	7
420	PEI	7
420V	PEI	7
480	PEEK	6
490 HR	PEEK	6
500 HR	PTFE	1
520 HR	PAI	6
CMP LL5	PET	2
CMP XL20	PAI	10

Drilling Guidelines

	<i>TIVAR® UHMW-PE, Nylatron® PA6, Acetron® POM based materials</i>	<i>Proteus PP, Quadrant PC 1000, Quadrant PSU, Quadrant PPSU and Duratron® PEI based materials</i>	<i>Ertalyte® PET-P based materials</i>	<i>Symalit® PVDF and ECTFE based materials</i>
<i>Nominal Hole Diameter</i>	1/16" to 1/4" 1/2" to 3/4" 1" to >2"	1/16" to 1/4" 1/2" to 3/4" 1" to >2"	1/16" to 1/4" 1/2" to 3/4" 1" to >2"	1/16" to 1/4" 1/2" to 3/4" 1" to >2"
<i>Feed In./Rev.</i>	.007 to .015 .015 to .025 .020 to .050	.007 - .015 .015 - .025 .020 - .050	.002 - .005 .015 - .025 .020 - .050	.002 - .005 .015 - .025 .020 - .050

The recommended speed for drilling operations is 150 to 200 ft./min.

Drilling Tips

Smaller diameter holes

- High speed twist drills
- Peck drill suggested

Larger diameter holes

- Drill pilot hole
- Use slow speed spiral drills or inserted drills

Ketron® PEEK based materials	Fluorosint® PTFE (1) based materials	Techtron® PPS based materials	Duratron® PAI and Duratron® PI based materials	Duratron® PBI based materials
1/16" to 1/4" 1/2" to 3/4" 1" to >2"	1/16" to 1/4" 1/2" to 3/4" 1" to >2"	1/16" to 1/4" 1/2" to 3/4" 1" to >2"	1/16" to 1/4" 1/2" to 3/4" 1" to >2"	1/2" or larger
.002 - .005 .004 - .008 .008 - .012	.007 - .015 .015 - .025 .020 - .050	.007 - .015 .015 - .025 .020 - .050	.007 - .015 .015 - .025 .020 - .050	.015 - .025

(1) For Fluorosint® MT01 PTFE contact Quadrant's Technical Service Team

Drilling

Difficulty

Common Cause

<i>Tapered Hole</i>	<ol style="list-style-type: none"> 1. Incorrectly sharpened drill 2. Insufficient clearance 3. Feed too heavy
<i>Burnt or Melted Surface</i>	<ol style="list-style-type: none"> 1. Wrong type drill 2. Incorrectly sharpened drill 3. Feed too light 4. Dull drill 5. Web too thick 6. Not peck drilling
<i>Chipping of Surfaces</i>	<ol style="list-style-type: none"> 1. Feed too heavy 2. Clearance too great 3. Too much rake (thin web as described)
<i>Chatter</i>	<ol style="list-style-type: none"> 1. Too much clearance 2. Feed light 3. Drill overhang too great 4. Too much rake (thin web as described)
<i>Feed Marks or Spiral Lines on Inside Diameter</i>	<ol style="list-style-type: none"> 1. Feed too heavy 2. Drill not centered 3. Drill ground off-center
<i>Oversize Holes</i>	<ol style="list-style-type: none"> 1. Drill ground off-center 2. Web too thick 3. Insufficient clearance 4. Feed rate too heavy 5. Point angle too great
<i>Undersize Holes</i>	<ol style="list-style-type: none"> 1. Dull drill 2. Too much clearance 3. Point angle too small
<i>Holes Not Concentric</i>	<ol style="list-style-type: none"> 1. Feed too heavy 2. Spindle speed too slow 3. Drill enters next piece too far 4. Cut-off tool leaves nib, which deflects drill 5. Web too thick 6. Drill speed too heavy at start 7. Drill not mounted on center 8. Drill not sharpened correctly

Burr at Cut-off

1. Dull cut-off tool
2. Drill does not pass completely through piece

Rapid Dulling of Drill

1. Feed too light of drill
2. Spindle speed too fast
3. Insufficient lubrication from coolant

NOTES

Sawing Guidelines

	TIVAR® UHMW-PE, Nylatron® PA6, Acetron® POM based materials				Proteus® PP, Quadrant PC 1000, Quadrant PSU, Quadrant PPSU and Duratron® PEI based materials				Ertalyte® PET-P based materials				Symalit® PVDF and ECTFE based materials			
Material Thickness	<.5"	.5"-1.0"	1.0"-3.0"	>3.0"	<.5"	.5"-1.0"	1.0"-3.0"	>3.0"	<.5"	.5"-1.0"	1.0"-3.0"	>3.0"	<.5"	.5"-1.0"	1.0"-3.0"	>3.0"
Band Speeds Ft./Min.	3,000	2,500	2,000	1,500	4,000	3,500	3,000	2,500	5,000	4,300	3,500	3,000	4,000	3,500	3,000	2,500
Pitch Teeth/In.	10-14	6	3	3	10-14	6	3	3	10-14	6	3	3	10-14	6	3	3
Tooth Form	Precision		Butress		Precision		Butress		Precision		Butress		Precision		Butress	

<i>Ketron® PEEK based materials</i>				<i>Fluorosint® PTFE (1) based materials</i>				<i>Techtron® PPS based materials</i>				<i>Duratron® PAI and Duratron® PI based materials</i>				<i>Duratron® PBI based materials</i>		
<i><.5"</i>	<i>.5"-1.0"</i>	<i>1.0"-3.0"</i>	<i>>.3.0"</i>	<i><.5"</i>	<i>.5"-1.0"</i>	<i>1.0"-3.0"</i>	<i>>.3.0"</i>	<i><.5"</i>	<i>.5"-1.0"</i>	<i>1.0"-3.0"</i>	<i>>.3.0"</i>	<i><.5"</i>	<i>.5"-1.0"</i>	<i>1.0"-3.0"</i>	<i>>.3.0"</i>	<i>.375"-1.0"</i>	<i>1.0"-2.0"</i>	
4,000	3,500	3,000	2,500	3,000	2,500	2,000	1,500	5,000	4,300	3,500	3,000	5,000	4,300	3,500	3,000	3,000	1,500	
10-14	6-8	3	3	10-14	6-8	3	3	10-14	6-8	3	3	10-14	6-8	3	3	10	10	
<i>Precision</i>		<i>Butress</i>		<i>Precision</i>		<i>Butress</i>		<i>Precision</i>		<i>Butress</i>		<i>Precision</i>		<i>Butress</i>		<i>Precision</i>		<i>Butress</i>

(1) For Fluorosint® MT01 PTFE contact Quadrant's Technical Service Team

End Milling/ Slotting Guidelines

	TIVAR® UHMW-PE, Nylatron® PA6, Acetron® POM based materials	Proteus PP, Quadrant PC 1000, Quadrant PSU, Quadrant PPSU and Duratron® PEI based materials	Ertalyte® PET-P based materials	Symalit® PVDF and ECTFE based materials
Recommend Carbide	1/4", 1/2", 3/4", 1", 2", 1/4", 1/2", 3/4"	1/4", 1/2", 3/4", 1", 2", 1/4", 1/2", 3/4"	1/4", 1/2", 3/4", 1", 2", 1/4", 1/2", 3/4"	1/4", 1/2", 3/4", 1", 2", 1/4", 1/2", 3/4"
Depth of Cut	0.250 0.050	0.250 0.050	0.250 0.050	0.250 0.050
Speed, Feet/Min.	270 - 450 300 - 500	270 - 450 300 - 500	270 - 450 300 - 500	270 - 450 300 - 500
Feed, In./Min.	0.002, 0.003, 0.005, 0.008, 0.001, 0.002, 0.004	0.002, 0.003, 0.005, 0.008, 0.001, 0.002, 0.004	0.002, 0.003, 0.005, 0.008, 0.001, 0.002, 0.004	0.002, 0.003, 0.005, 0.008, 0.001, 0.002, 0.004

Milling Tips

Climb milling is recommended over conventional milling (See Diagram 1, Page 31)

<i>Ketron® PEEK based materials</i>	<i>Fluorosint® PTFE (1) based materials</i>	<i>Techtron® PPS based materials</i>	<i>Duratron® PAI and Duratron® PI based materials</i>	<i>Duratron® PBI based materials</i>
<i>1/4", 1/2", 3/4", 1", 2", 1/4", 1/2", 3/4"</i>	<i>1/4", 1/2", 3/4", 1", 2", 1/4", 1/2", 3/4"</i>	<i>1/4", 1/2", 3/4", 1", 2", 1/4", 1/2", 3/4"</i>	<i>1/4", 1/2", 3/4", 1", 2", 1/4", 1/2", 3/4"</i>	<i>1/4", 1/2", 3/4", 1", 2", 1/4", 1/2", 3/4"</i>
<i>0.150 0.060</i>	<i>0.150 0.060</i>	<i>0.150 0.060</i>	<i>0.035</i>	<i>0.015</i>
<i>500 - 750</i>	<i>500 - 700 550 - 750</i>	<i>1300 - 1500 1500 - 2000</i>	<i>500 - 800</i>	<i>250 - 350</i>
<i>0.020 0.005</i>	<i>0.010 0.005</i>	<i>0.020 0.005</i>	<i>0.006 - 0.035</i>	<i>0.002 - 0.006</i>

(1) For Fluorosint® MT01 PTFE contact Quadrant's Technical Service Team

Face Milling (C-2, Carbide Tool)

	<i>TIVAR® UHMW-PE, Nylatron® PA6, Acetron® POM based materials</i>	<i>Proteus PP, Quadrant PC 1000, Quadrant PSU, Quadrant PPSU and Duratron® PEI based materials</i>	<i>Ertalyte® PET-P based materials</i>	<i>Symalit® PVDF and ECTFE based materials</i>
<i>Depth of Cut</i>	<i>0.150 0.060</i>	<i>0.150 0.060</i>	<i>0.150 0.060</i>	<i>0.150 0.060</i>
<i>Speed, Feet/Min.</i>	<i>1300 - 1500 1500 - 2000</i>	<i>1300 - 1500 1500 - 2000</i>	<i>1300 - 1500 1500 - 2000</i>	<i>1300 - 1500 1500 - 2000</i>
<i>Feed, In./Min.</i>	<i>0.020 0.005</i>	<i>0.020 0.005</i>	<i>0.020 0.005</i>	<i>0.020 0.005</i>

<i>Ketron® PEEK based materials</i>	<i>Fluorosint® PTFE (1) based materials</i>	<i>Techtron® PPS based materials</i>	<i>Duratron® PAI and Duratron® PI based materials</i>	<i>Duratron® PBI based materials</i>
<i>0.150 0.060</i>	<i>0.150 0.060</i>	<i>0.150 0.060</i>	<i>0.035</i>	<i>0.015</i>
<i>500 - 750</i>	<i>500 - 700 550 - 750</i>	<i>1300 - 1500 1500 - 2000</i>	<i>500 - 800</i>	<i>250 - 350</i>
<i>0.020 0.005</i>	<i>0.010 0.005</i>	<i>0.020 0.005</i>	<i>.006 - .035</i>	<i>.002 - .006</i>

(1) For Fluorosint® MT01 PTFE contact Quadrant's Technical Service Team

Turning & Boring

21

Difficulty

Common Cause

Melted Surface

1. Tool dull or heel rubbing
2. Insufficient side clearance
3. Feed rate too slow
4. Spindle speed too fast

Rough Finish

1. Feed too heavy
2. Incorrect clearance angles
3. Sharp point on tool (slight nose radius required)
4. Tool not mounted on center

Burrs at Edge of Cut

1. No chamfer provided at sharp corners
2. Dull tool
3. Insufficient side clearance
4. Lead angle not provided on tool (tool should ease out of cut gradually, not suddenly)

Cracking or Chipping of Corners

1. Too much positive rake on tool
2. Tool not eased into cut (tool suddenly hits work)
3. Dull tool
4. Tool mounted below center
5. Sharp point on tool (slight nose radius required)

Chatter

1. Too much nose radius on tool
2. Tool not mounted solidly
3. Material not supported properly
4. Width of cut too wide (use 2 cuts)

NOTES

Cutting Off

Difficulty

Common Cause

Melted Surface

1. Dull tool
2. Insufficient side clearance
3. Insufficient coolant supply

Rough Finish

1. Feed too heavy
2. Tool improperly sharpened
3. Cutting edge not honed

Spiral Marks

1. Tool rubs during its retreat
2. Burr on point of tool

Concave or Convex Surfaces

1. Point angle too great
2. Tool not perpendicular to spindle
3. Tool deflecting
4. Feed too heavy
5. Toolmounted above or below center

Nibs or Burrs at Cut-off Point

1. Point angle not great enough
2. Tool dull
3. Feed too heavy

Burrs on Outside Diameter

1. No chamfer before cut-off diameter
2. Dull tool

NOTES

Turning Guidelines (C-2, Carbide Tool)

	TIVAR® UHMW-PE, Nylatron® PA6, Acetron® POM based materials	Proteus PP, Quadrant PC 1000, Quadrant PSU, Quadrant PPSU and Duratron® PEI based materials	Ertalyte® PET-P based materials	Symalit® PVDF and ECTFE based materials
Depth of Cut	.150" deep cut .025" deep cut	.150" deep cut .025" deep cut	.150" deep cut .025" deep cut	.150" deep cut .025" deep cut
Speed, Feet/Min.	500 - 600 600 - 700	500 - 600 600 - 700	500 - 600 600 - 700	500 - 600 600 - 700
Feed, In./Rev.	.010 - .015 .004 - .007	.010 - .015 .004 - .007	.010 - .015 .004 - .007	.010 - .015 .004 - .007

Turning Tips

Inserts with positive geometries and ground peripheries

- Use Recommended Turning Tooling Geometry (See Diagram 2, page 32).

<i>Ketron® PEEK based materials</i>	<i>Fluorosint® PTFE (1) based materials</i>	<i>Techtron® PPS based materials</i>	<i>Duratron® PAI and Duratron® PI based materials</i>	<i>Duratron® PBI based materials</i>
<i>.150" deep cut .025" deep cut</i>	<i>.150" deep cut .025" deep cut</i>	<i>.150" deep cut .025" deep cut</i>	<i>.025" deep cut</i>	<i>.025" deep cut</i>
<i>350 - 500 500 - 600</i>	<i>600 - 1000 600 - 700</i>	<i>100 - 300 250 - 500</i>	<i>300 - 800</i>	<i>150 - 225</i>
<i>.010 - .015 .003 - .008</i>	<i>.010 - .016 .004 - .007</i>	<i>.010 - .020 .005 - .010</i>	<i>.004 - .025</i>	<i>.002 - .006</i>

(1) For Fluorosint® MT01 PTFE contact Quadrant's Technical Service Team

When should parts be annealed after machining to ensure optimum part performance?

Experience has shown us that very few machined plastic parts require annealing after machining to meet dimensional or performance requirements.

All Quadrant stock shapes are annealed using a proprietary stress relieving cycle to minimize any internal stresses that may result from the manufacturing process. This assures you that the material will remain dimensionally stable during and after machining.

Machined-in stress can reduce part performance and lead to premature part failure. To prevent machined-in stress, it is important to identify the causes.

ANNEALING

Machined-in stress is created by:

- ***Using dull or improperly designed tooling***
- ***Excessive heat – generated from inappropriate speeds and feed rates***
- ***Machining away large volumes of material – usually from one side of the stock shape***

To reduce the potential for machined-in stress, review the fabrication guidelines for the specific material. Recognize that guidelines change as the material type changes.

:: POST MACHINING

Benefits of Post-Machining Annealing

Improved Chemical Resistance

Polycarbonate, polysulfone, and Duratron® PEI, like many amorphous (transparent) plastics may be annealed to minimize stress crazing. Duratron® PAI also benefits from post machining annealing. Annealing finished parts becomes more important as machining volume increases. Annealing after machining reduces “machined-in” stresses that can contribute to premature failure.

Better Flatness and Tighter Tolerance Capability

Extremely close-tolerance parts requiring precision flatness and non-symmetrical contour sometimes require intermediate annealing between machining operations. Improved flatness can be attained by rough machining, annealing and finish machining with a very light cut. Balanced machining on both sides of the shape centerline can also help prevent warpage.

Improved Wear Resistance

Extruded or injection molded Duratron® PAI parts that require high PV's or the lowest possible wear factor benefit from an additional cure after machining. This curing process optimizes the wear properties. Only Duratron® PAI benefits from such a cycle.

Post Machining Air Annealing Guidelines

Material	Heat Up	Hold
<i>Type 6 Nylons</i>	<i>4 hours to 300° F</i>	<i>30 minutes per 1/4" thickness</i>
<i>Type 6/6 Nylons</i>	<i>4 hours to 350° F</i>	<i>30 minutes per 1/4" thickness</i>
<i>Ertalyte® PET-P</i>	<i>4 hours to 350° F</i>	<i>30 minutes per 1/4" thickness</i>
<i>Acetron® GP POM-C</i>	<i>4 hours to 310° F</i>	<i>30 minutes per 1/4" thickness</i>
<i>Acetron® POM-H</i>	<i>4 hours to 320° F</i>	<i>30 minutes per 1/4" thickness</i>
<i>Quadrant PC 1000</i>	<i>4 hours to 275° F</i>	<i>30 minutes per 1/4" thickness</i>
<i>Quadrant PSU</i>	<i>4 hours to 330° F</i>	<i>30 minutes per 1/4" thickness</i>

Cool Down**Environment***50° F per hour**Oil or Nitrogen**50° F per hour**Oil or Nitrogen**50° F per hour**Oil or Nitrogen**50° F per hour**Nitrogen or Air**50° F per hour**Nitrogen or Air**50° F per hour**Air**50° F per hour**Air***Tips to Succeed**

- *Ensure parts are fixtured to desired shape or flatness.*
- *Do not unfixture until parts have completed entire cycle and are cool to the touch.*
- *Do not take short-cuts.*

Finish machining of critical dimensions should be performed after annealing.

Important: Annealing cycles have been generalized to apply to a majority of machined parts. Changes in heat up and hold time may be possible if cross sections are thin. Parts should be fixtured during annealing to prevent distortion.

Post Machining Air Annealing Guidelines *cont'd.*

Material	Heat Up	Hold
<i>Quadrant PPSU Duratron® PEI</i>	<i>4 hours to 390° F</i>	<i>30 minutes per 1/4" thickness</i>
<i>Techtron® PPS</i>	<i>4 hours to 350° F</i>	<i>30 minutes per 1/4" thickness</i>
<i>Ketron® PEEK</i>	<i>4 hours to 300° F 4 hours to 375° F</i>	<i>60 minutes per 1/4" thickness 60 minutes per 1/4" thickness</i>
<i>Duratron® PAI</i>	<i>4 hours to 300° F 4 hours to 420° F 4 hours to 470° F 4 hours to 500° F</i>	<i>1 day 1 day 1 day 3 to 10 days</i>
<i>Duratron® PI</i>	<i>4 hours to 300° F 4 hours to 450° F 4 hours to 600° F</i>	<i>60 minutes per 1/4" thickness 60 minutes per 1/4" thickness</i>

Cool Down**Environment***50° F per hour**Nitrogen or Air**50° F per hour**Air**50° F per hour**Air**50° F per hour**Air**50° F per hour**Air***Tips to Succeed**

- *Ensure parts are fixtured to desired shape or flatness.*
- *Do not unfixture until parts have completed entire cycle and are cool to the touch.*
- *Do not take short-cuts.*

Finish machining of critical dimensions should be performed after annealing.

Important: Annealing cycles have been generalized to apply to a majority of machined parts. Changes in heat up and hold time may be possible if cross sections are thin. Parts should be fixtured during annealing to prevent distortion.

Climb Milling vs. Conventional Milling

DIAGRAM 1

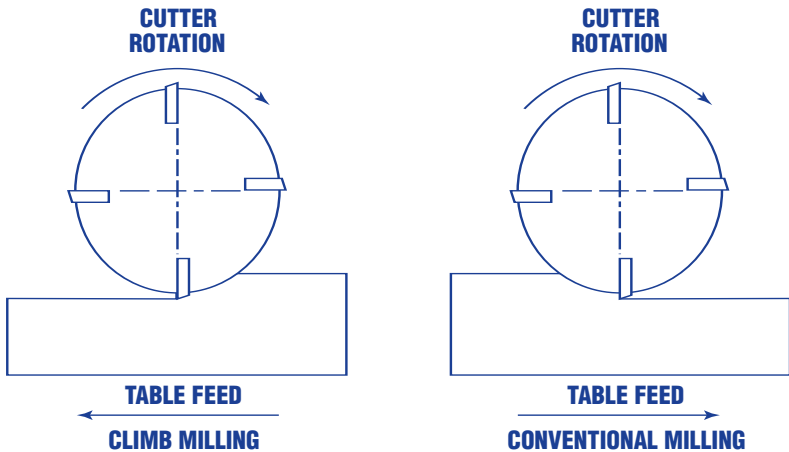

Recommended Turning Tooling Geometry

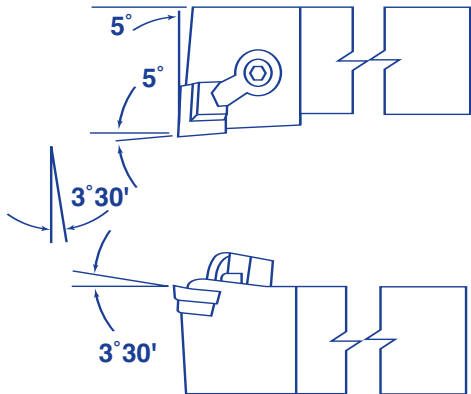

CPG

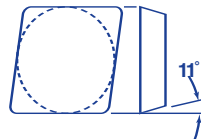

DIAGRAM 2

Conversions

Fractions	Decimal	MM
1/64	.0156	0.396
1/32	.0312	0.793
3/64	.0468	1.190
1/16	.0625	1.587
5/64	.0781	1.984
3/32	.0937	2.381
7/64	.1093	2.778
1/8	.125	3.175
9/64	.1406	3.571
5/32	.1562	3.968
11/64	.1718	4.365
3/16	.1875	4.762
13/64	.2031	5.159
7/32	.2187	5.556
15/64	.2343	5.953
1/4	.250	6.350
17/64	.2656	6.746
9/32	.2812	7.143
19/64	.2968	7.540
5/16	.3125	7.937
21/64	.3281	8.334
11/32	.3437	8.731
23/64	.3593	9.128
3/8	.375	9.525
25/64	.3906	9.921
13/32	.4062	10.318
27/64	.4218	10.715
7/16	.4375	11.112
29/64	.4531	11.509
15/32	.4687	11.906
31/64	.4843	12.303
1/2	.500	12.700
33/64	.5156	13.096
17/32	.5312	13.493
35/64	.5468	13.890
9/16	.5625	14.287

37/64	.5781	14.684
19/32	.5937	15.081
39/64	.6093	15.478
5/8	.625	15.875
41/64	.6406	16.271
21/32	.6562	16.668
43/64	.6718	17.065
11/16	.6875	17.462
45/64	.7031	17.859
23/32	.7187	18.256
47/64	.7343	18.653
3/4	.750	19.050
49/64	.7656	19.446
25/32	.7812	19.843
51/64	.7968	20.240
13/16	.8125	20.637
53/64	.8281	21.034
27/32	.8437	21.431
55/64	.8593	21.828
7/8	.875	22.225
57/64	.8906	22.621
29/32	.9062	23.018
59/64	.9218	23.415
15/16	.9375	23.812
61/64	.9531	24.209
31/32	.9687	24.606
63/64	.9843	25.003
1	1.000	25.400

NOTES

Notes

Notes

Quadrant Engineering Plastic Products

Regional Headquarters

EUROPE

Hardstrasse 5
 CH-5600 Lenzburg
 Tel +41 (0) 62 8858150
 Fax +41 (0) 62 8858181
 e-mail: info@qplas.com

NORTH AMERICA

2120 Fairmont Avenue
 PO Box 14235 - Reading, PA 19612-4235
 Tel (800) 366 0300 / +1 610 320 6600
 Fax (800) 366 0301 / +1 610 320 6868
 e-mail: americas.epp@qplas.com

ASIA-PACIFIC

60 Ha Mei San Tsuen, Ping Shan
 YUEN LONG,
 N.T. Hong Kong
 Tel +852 (0) 24702683
 Fax +852 (0) 24789966
 e-mail: asia.epp@qplas.com

All statements, technical information and recommendations contained in this publication are presented in good faith, based upon tests believed to be reliable and practical field experience. The reader is cautioned, however, that Quadrant Engineering Plastic Products does not guarantee the accuracy or completeness of this information and it is the customer's responsibility to determine the suitability of Quadrant's products in any given application.

Acetron, Duraspin, Duratron, Erta, Ertacetal, Ertalene, Ertalon, Ertalyte, Extreme Materials, Fluorosint, Ketron, MC, Monocast, Novatron, Nylatrack, Nylatron, Polypenco, Proteus, Sanalite, Semitron, Symalit, Techtron, TIVAR, Ultrawear and Vibratuf are registered trademarks of the Quadrant group of companies.

*Classix is a registered trademark of Invibio Ltd. Corp.

*Rulon is a registered trademark of Saint Gobain Performance Plastics

*Torlon is a registered trademark of Solvay Advanced Polymers

*Vespel is a registered trademark of E.I. DuPont

This guide was created by Quadrant Engineering Plastic Products. Design and content are protected by copyright law. © 2010 Quadrant Engineering Plastic Products.

Visit our website for additional information: www.quadrantplastics.com

Thermoplastics & Thermosets

Plastics are commonly described as being either a thermoplastic (meltable) or a thermoset (non meltable). Thermoset materials such as phenolic and epoxy were developed as early as 1900 and were some of the earliest “high volume” plastics. Both thermoplastic and thermoset stock shapes are available for machined parts, although thermoplastic stock shapes are much more commonly used today. Their ease of fabrication, self-lubricating characteristics, and broad size and shape availability make thermoplastics ideal for bearing and wear parts as well as structural components.



www.quadrantplastics.com
800.366.0300



**WANT TO KNOW MORE?
WE'RE READY TO HELP.**



QUADRANT

You inspire... we make it real!